

nifty

HR15

**SELF PROPELLED
ACCESS PLATFORM**



15.75m (51ft 8in)
Working height

9.60m (31ft 6in)
Working outreach

2.00m Chassis Width
Allowing operation in
confined areas

45% Gradeability
4WD for rough terrain

**Fully Proportional
Hydraulic Controls**
Simple, reliable &
easy to maintain

1.80m Wide Platform
More room for tools
& equipment

**Platform Rotation
& Flyboom**
Improved access to applications



niftylift.com



nifty

Heightrider 15

The Nifty **Height Rider 15** offers one of the best working envelopes in its class and its compact yet robust base allows it to manoeuvre easily in restricted areas. A huge 1.80m wide platform provides more room for materials and tools and a 150° flyboom with 180° platform rotation, helps to increase accuracy when positioning. Operation and maintenance are simple due to fully proportional hydraulic controls and the 4WD allows the **HR15** to travel over rough and uneven ground.

SAFETY FEATURES

- Manual Recovery with Hand Pump
- Dual Controls (Platform & Base)
- Dual Harness Points
- Tilt Alarm
- CE Mark
- Foam Filled Tyres
- Automatic Failsafe Brakes
- Lock Valves on all Hydraulic Cylinders

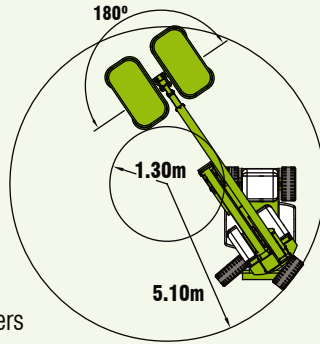

The unique suspension system shown above ensures maximum traction when travelling over uneven surfaces and the spacious 1.80m wide platform allows the operator ample room for tools and materials.

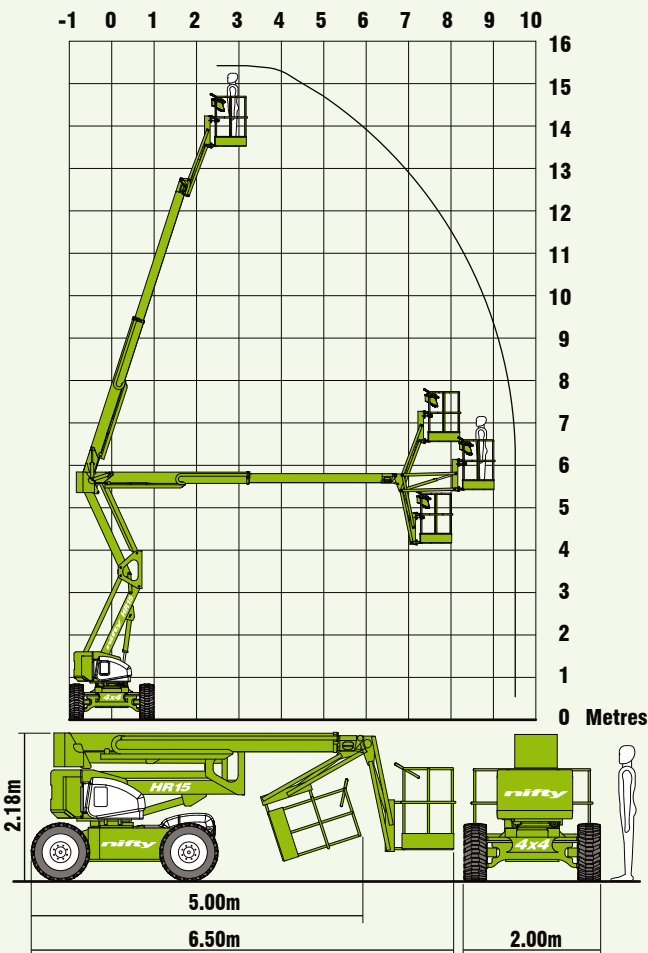

SPECIFICATIONS

Working Height	15.75m	51ft 8in
Platform Height	13.75m	45ft 1in
Working Outreach	9.60m	31ft 6in
Slew	360°	
Flyboom Arc	150°	
Width	2.00m	6ft 7in
Height	2.18m	7ft 2in
Length - Overall	6.50m	21ft 4in
- Stowed	5.00m	16ft 5in
Minimum Weight	6,100kg*	13,450lbs*
Turning Radius - Inside	1.30m	4ft 3in
- Outside	5.10m	16ft 9in
Platform Rotation	180°	
Platform Capacity	225kg	500lbs
Platform Size	1.80m x 0.70m	5ft 11in x 2ft 4in
Drive Speed	6.6kph	4.1mph
Gradeability	45%	
Power System	Kubota 1505 32Hp	

* Weights may vary according to specification, please confirm before ordering.

Due to a policy of continuing development and improvement, Niftylift reserves the right to change any specification without notice. Please confirm exact specification before ordering.

Supplied by:



T: 01332 856 359 F: 01332 810 769

E: info@workplatformltd.co.uk W: www.workplatformltd.co.uk

IS-05

Manufacturers of trailer mounted, self propelled and vehicle mounted platforms.



NIFTYLIFT LTD
Fingle Drive
Stonebridge
Milton Keynes
MK13 0ER
England

www.niftylift.com

e-mail: info@niftylift.com
Tel.: +44 (0) 1908 223456
Fax.: +44 (0) 1908 312733