



JLG E450 SERIES

- Choice of models with up to a working height of 15 m
- Articulating Jib feature available for improved positioning
- On-board generator for quick charging of batteries
- Multiple function operation gets you to the job quicker
- Proportional controls achieve smoother movement for operator comfort
- Automatic Traction Control (ATC) for improved manoeuvrability on off-slab areas

For more details check the JLG Technical Specification Guide or ask your local JLG representative.



Performance Advantages

Provides greater productivity for the operator with the fastest boom speeds in its class.



Automatic Traction Control (ATC) for higher performance

Advanced control system ensures improved traction on uneven surfaces or over floor obstacles.



Articulating Jib*

Allows for greater versatility when positioning the platform around obstacles.

* Models E450AJ and M450AJ only



Multi-Power System

M450A and M450AJ models feature an engine-powered generator that automatically recharges the batteries to help reduce downtime.



Easy to follow layout of controls

Console designed for ease of operation and rapid positioning control.



Operator's Tool Tray

Provides a handy storage area for tools, fasteners and other work materials.



T: 01332 856 359 F: 01332 810 769

E: info@workplatformltd.co.uk W: www.workplatformltd.co.uk

JLGEUROPE

JLG Industries (Europe), A Division of JLG Industries, Inc.
Kilmartin Place, Tannochside Park,
Uddingston, G71 5PH, Scotland.
Tel: 01698 811005
Fax: 01698 811055

www.jlg.com



E450 SERIES ELECTRIC ARTICULATING BOOM LIFTS

	E450A	M450A	E450AJ	M450AJ
Platform Height	13.72 m	13.72 m	13.72 m	13.72 m
Horizontal Outreach	7.04 m	7.04 m	7.24 m	7.24 m
Up and Over Height	7.49 m	7.49 m	7.70 m	7.70 m
Swing (non-continuous)	360°	360°	360°	360°
Platform Capacity – Unrestricted	230 kg	230 kg	230 kg	230 kg
Platform Rotator (Hydraulic)	180°	180°	180°	180°
Jib – Overall Length	—	—	1.24 m	1.24 m
Jib - Range of articulation	—	—	141° (+86°/-55°)	141° (+86°/-55°)
A. Platform Size	0.76 m x 1.52 m	0.76 m x 1.52 m	0.76 m x 1.52 m	0.76 m x 1.52 m
B. Overall Width	1.75 m	1.75 m	1.75 m	1.75 m
C. Tailswing (working condition)	Zero	Zero	Zero	Zero
D. Stowed Height	1.98 m	1.98 m	2.01 m	2.01 m
E. Stowed Length	5.82 m	5.82 m	6.45 m	6.45 m
F. Wheelbase	2.01 m	2.01 m	2.01 m	2.01 m
G. Ground Clearance	0.22 m	0.22 m	0.22 m	0.22 m
Gross Vehicle Weight*	5,780 kg	5,780 kg	6,532 kg	6,532 kg
Drive Speed	5.2 km/h	5.2 km/h	5.2 km/h	5.2 km/h
Gradeability	30%	30%	30%	30%
Tyres	240/55-17.5 Pneumatic	240/55-17.5 Pneumatic	240/55-17.5 Foam Filled	240/55-17.5 Foam Filled
Turning Radius – Inside	0.61 m	0.61 m	0.61 m	0.61 m
Turning Radius – Outside	3.15 m	3.15 m	3.15 m	3.15 m
Electrical System	48V DC	48V DC	48V DC	48V DC
Batteries	8 x 6V 370 A/hr	8 x 6V 370 A/hr	8 x 6V 370 A/hr	8 x 6V 370 A/hr
Drive Motors	Dual Electric Traction	Dual Electric Traction	Dual Electric Traction	Dual Electric Traction
Brakes	Automatic Spring Applied	Automatic Spring Applied	Automatic Spring Applied	Automatic Spring Applied
Hydraulic Motor	Perm. Magnet	Perm. Magnet	Perm. Magnet	Perm. Magnet
Hydraulic Pump	Gear Pump	Gear Pump	Gear Pump	Gear Pump
Hydraulic Reservoir	15 L	15 L	15 L	15 L
Generator Set - Fully Automatic	—	Yanmar Air-cooled 4 kW	—	Yanmar Air-cooled 4 kW
Generator Fuel Tank	—	15 L	—	15 L

*Certain options or country standards will increase weight.
Specifications may change to meet country standards or with the addition of optional equipment.

JLG MODELS E450A & M450A

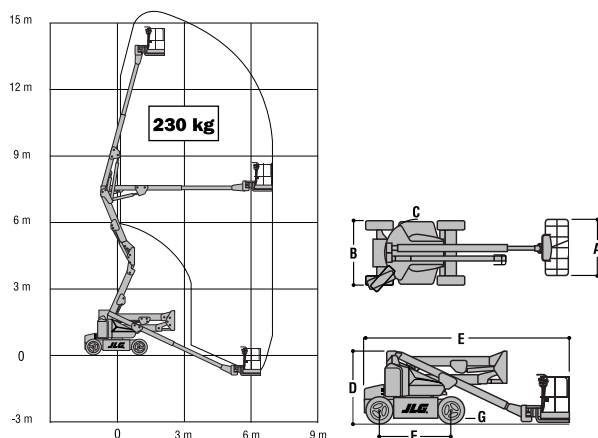

JLG MODELS E450AJ & M450AJ

