

## JLG 800 SERIES



- Choice of models with up to 26 m working height
- Exclusive QuikStik™ Boom provides faster duty cycles up and down
  - Fast boom and drive speeds improve work productivity
  - Multiple simultaneous boom functions get you to the job quicker
- Proportional controls achieve smoother movement for operator comfort
- Excellent manoeuvrability for positioning of machine and platform
- Handle the roughest of terrain with increased engine power

For more details check the JLG Technical Specification Guide or ask your local JLG representative.



### The Industry's Best Reach Envelope

Delivers 9.75 m of up and over clearance, and over 15.5 m horizontal outreach\*.  
\*Model 800A - 16.15 m  
Model 800AJ - 15.74 m



### Articulating Jib\*

Allows for greater versatility when positioning the platform around obstacles.  
\*Model 800AJ only.



### QuikStik™ Boom provides optimum productivity

Unique feature that links two lifting actions, allowing the operator to go from the ground level to full elevation in less than 50 seconds (the same applies when lowering the boom).



### Controls designed for ease of operation

Easier to operate when positioning and controlling movement.



### Oscillating axle option for tough travel

Provides increased traction when travelling.



### Greater serviceability

Improved access with an engine swing-out tray.



T: 01332 856 359 F: 01332 810 769

E: [info@workplatformltd.co.uk](mailto:info@workplatformltd.co.uk) W: [www.workplatformltd.co.uk](http://www.workplatformltd.co.uk)

### JLGEUROPE

JLG Industries (Europe), A Division of JLG Industries, Inc.  
Kilmartin Place, Tannochside Park,  
Uddingston, G71 5PH, Scotland.  
Tel: 01698 811005  
Fax: 01698 811055

[www.jlg.com](http://www.jlg.com)



# 800 SERIES ARTICULATING BOOM LIFTS

	<b>800A</b>	<b>800AJ</b>
Platform Height	24.38 m	24.38 m
Horizontal Outreach	16.15 m	15.74 m
Up and Over Height	9.78 m	9.78 m
Swing (Continuous)	360°	360°
Platform Capacity – Unrestricted	230 kg	230 kg
Platform Rotator (Hydraulic)	180°	180°
Jib – Overall Length	—	1.83 m
Jib - Range of articulation	—	130° (+70°/ -60°)
A. Platform Size	0.91 m x 1.83 m	0.91 m x 1.83 m
B. Overall Width	2.44 m	2.44 m
C. Tailswing –working condition	0.76 m	0.76 m
D. Stowed Height	3.00 m	3.00 m
E. Stowed Length	11.25 m	11.12 m
F. Wheelbase	3.05 m	3.05 m
G. Ground Clearance	0.30 m	0.30 m
Gross Vehicle Weight*	15,030 kg	15,030 kg
Maximum Ground Bearing Pressure	5.36 kg/cm <sup>2</sup>	5.36 kg/cm <sup>2</sup>
Drive Speed 2WD	4.8 km/h	4.8 km/h
Drive Speed 4WD	4.8 km/h	4.8 km/h
Gradeability 2WD	30%	30%
Gradeability 4WD	45%	45%
Tyres	15 x 19,5 Foam Filled	15 x 19,5 Foam Filled
Axle Oscillation (optional)	0.20 m	0.20 m
Turning Radius – Inside 2WS	3.66 m	3.66 m
Turning Radius – Inside 4WS	2.13 m	2.13 m
Turning Radius – Outside 2WS	6.86 m	6.86 m
Turning Radius – Outside 4WS	4.42 m	4.42 m
Diesel Engine – Deutz F4M1011E	48.5 kW	48.5 kW
Fuel Tank Capacity	147.6 L	147.6 L
Hydraulic Reservoir	151.4 L	151.4 L
Auxiliary Power	12V DC	12V DC

\*Certain options or country standards will increase weight.

Specifications may change to meet country standards or with the addition of optional equipment.

## JLG MODEL 800A

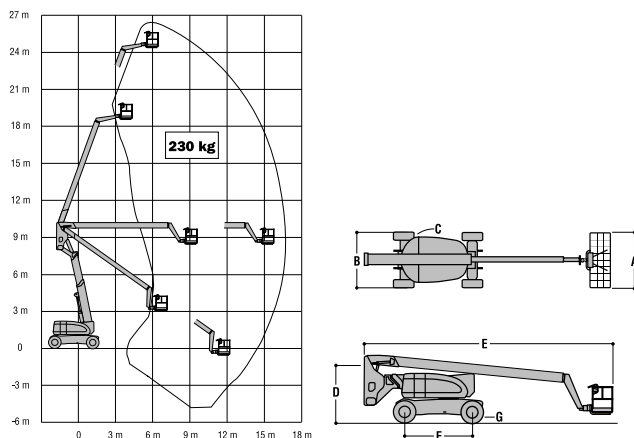

## JLG MODEL 800AJ

