

JLG 600 CRAWLER SERIES



- Choice of models with working heights from 20 m to 22 m*
- Steel crawler tracks provide incredible 55% gradeability
- Increased manoeuvrability on soft terrain due to 0.4 kg/cm² low ground bearing pressure
 - Fast boom and drive speeds improve work productivity
 - Multiple simultaneous boom functions get you to the job quicker
- Single drive/steer joystick proportional controls achieve smoother movement for operator comfort
- Excellent manoeuvrability for positioning of machine and platform

* Model 600SC & 600SJC - 20 m working height
Model 660SJC - 22 m working height

For more details check the JLG Technical Specification Guide or ask your local JLG representative.



Greater Terrainability

With a 55% gradeability, this boom lift can go anywhere it needs to go.

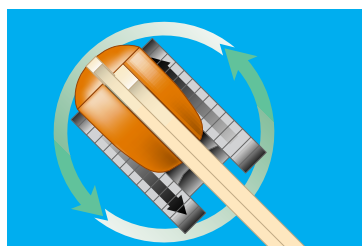

Faster Positioning

Tracks move in opposite directions to provide a zero turning radius for faster positioning.



Single Drive/Steer Joystick Controller

The intuitive single drive/steer joystick makes it simpler to control when driving.



Articulating Jib*

Allows for greater versatility when positioning the platform around obstacles.
*Model 600SJC & 660SJC only.



Low Ground Bearing Pressure

Improves manoeuvrability when travelling on wet ground or sand.



Greater serviceability

Improved access with an engine swing-out tray.



T: 01332 856 359 F: 01332 810 769

E: info@workplatformltd.co.uk W: www.workplatformltd.co.uk

JLGEUROPE

JLG Industries (Europe), A Division of JLG Industries, Inc.
Kilmartin Place, Tannochside Park,
Uddingston, G71 5PH, Scotland.
Tel: 01698 811005
Fax: 01698 811055

www.jlg.com



600 CRAWLER SERIES TELESCOPIC BOOM LIFTS

	600SC	600SJC	660SJC
Platform Height	18.29 m	18.29 m	20.12 m
Horizontal Outreach	15.09 m	15.34 m	17.27 m
Swing (continuous)	360°	360°	360°
Platform Capacity – Unrestricted	230 kg	230 kg	230 kg
Platform Rotator (hydraulic)	160°	180°	180°
Jib – Overall Length	—	1.83 m	1.83 m
Jib - Range of articulation	—	130° (+70°/-60°)	130° (+70°/-60°)
A. Platform Size	0.91 m x 1.83 m	0.91 m x 1.83 m	0.91 m x 1.83 m
B. Overall Width	2.49 m	2.49 m	2.49 m
C. Tailswing (working condition)	1.14 m	1.14 m	1.14 m
D. Stowed Height	2.57 m	2.57 m	2.57 m
E. Overall Length	8.61 m	10.16 m	10.84 m
F. Stowed Length	8.61 m	9.55 m	10.31 m
G. Ground Clearance	0.38 m	0.38 m	0.38 m
Gross Vehicle Weight*	10,230 kg	11,160 kg	12,270 kg
Maximum Ground Bearing Pressure	0.383 kg/cm ²	0.425 kg/cm ²	0.457 kg/cm ²
Drive Speed	2.6 km/h	2.6 km/h	2.6 km/h
Gradeability	55%	55%	55%
Turning Radius	Zero	Zero	Zero
Type of Tracks**	Steel	Steel	Steel
Tracks Width	0.51 m	0.51 m	0.51 m
Diesel Engine (Deutz F4M1011F)	48.5 kW	48.5 kW	48.5 kW
Fuel Tank Capacity	148 L	148 L	148 L
Hydraulic Reservoir	117 L	117 L	117 L
Auxiliary Power	12V DC	12V DC	12V DC

*Certain options or country standards will increase weight. ** Optional detachable rubber pads available
Specifications may change to meet country standards or with the addition of optional equipment.

JLG MODEL 600SC

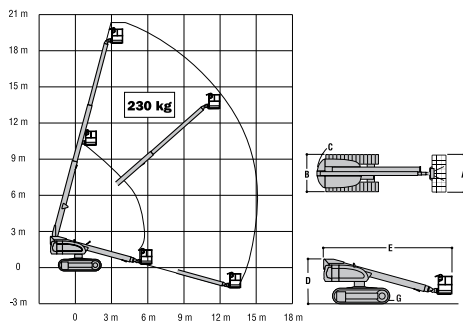

JLG MODEL 600SJC

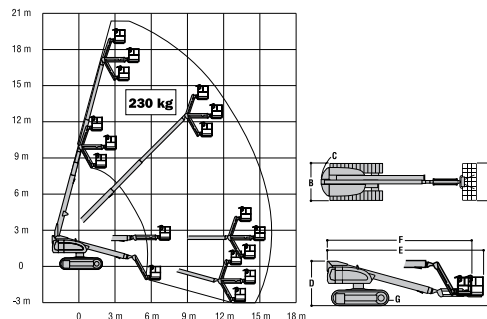

JLG MODEL 660SJC

