

**EASILY CONFIGURED TO MEET YOUR NEEDS**

**FORK**

- Load platform

**POWER**

- Standard winch

**BASE**

- Standard base

**WHEEL / CASTER OPTIONS**

- 20 cm (8 in) non-marking rear wheels
- Pneumatic 20 cm (8 in) rear wheels for rough terrain
- 5 cm (2 in) non-marking front swivel casters

**OPTIONS & ACCESSORIES**

**PRODUCTIVITY**

- 20 cm (8 in) non-marking rear wheels
- Pneumatic 20 cm (8 in) rear wheels for rough terrain
- 5 cm (2 in) non-marking front swivel casters
- Field-installable foot break

**STANDARD FEATURES**

**MEASUREMENTS**

- 1.70 m (5 ft 7 in) working height
- Up to 91 kg (200 lb) load capacity

**PRODUCTIVITY**

- Portable and compact design
- Lightweight durable aluminium construction
- High strength aircraft quality cable
- Cushioned neoprene hand grip
- Beveled aluminium platform for easy loading and unloading
- Portable - folds for compact storage
- 20 cm (8 in) non-marking rear wheels
- Stair glides for easy handling on stairs
- Hold-down mechanism secures for transport

**POWER**

- Standard quiet high-speed winch
- Reversible winch handle for easy storage



**Specifications**

MODEL		LOAD LIFTER™	
<b>MEASUREMENTS</b>		<b>Metric</b>	<b>US</b>
<b>A</b> Height - stowed		1.14 m	3 ft 9 in
Height - platform maximum		1.70 m	5 ft 7 in
<b>B</b> Length - stowed		38 cm	1 ft 3 in
Length - operating		73 cm	2 ft 4.75 in
<b>C</b> Width - stowed		52 cm	1 ft 8.5 in
<b>PRODUCTIVITY</b>			
Load capacity		91 kg	200 lbs
<b>D</b> Load height minimum		5 cm	2 in
Ground clearance - centre		2 cm	.75 in
Average cranks - standard winch		3 cranks/30 cm	3 cranks/ft
<b>E</b> Load platform length		36 cm	1 ft 2 in
<b>F</b> Load platform width		43 cm	1 ft 4.75 in
<b>POWER</b>			
Power source		reversible standard winch	
<b>WEIGHT*</b>			
		29 kg	65 lbs

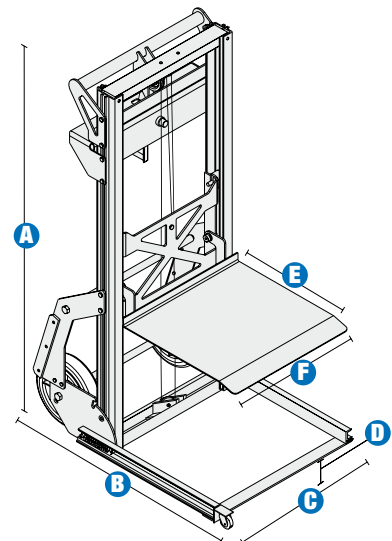

\* Weight will vary depending on options and/or country standards.

**Genie Europe**

Millennium House  
Brunel Drive  
Newark, NG24 2DE  
U.K.

Telephone **+44 (0)1476 584333**  
Fax +44 (0)1476 584334

Email: AWP-InfoEurope@terex.com

**Genie United States**

18340 NE 76th Street  
P.O. Box 97030  
Redmond, WA  
USA 98073-9730

Telephone **+1 (425) 881-1800**  
Fax +1 (425) 883-3475

**Distributed By:**



T: 01332 856 359 F: 01332 810 769

E: info@workplatformltd.co.uk W: www.workplatformltd.co.uk

Effective date: August, 2008. Product specifications are subject to change without notice or obligation. The photographs and/or drawings in this document are for illustrative purposes only. Refer to the appropriate Operator's Manual for instructions on the proper use of this equipment. Failure to follow the appropriate Operator's Manual when using our equipment or to otherwise act irresponsibly may result in serious injury or death. The only warranty applicable to our equipment is the standard written warranty applicable to the particular product and sale and we make no other warranty, expressed or implied. Products and services listed may be trademarks, service marks or trade-names of Terex Corporation, Genie Industries, Inc. and/or their subsidiaries in the U.S.A. and many other countries and all rights are reserved. Terex is a Registered Trademark of Terex Corporation in the U.S.A. and many other countries. Genie is a Registered Trademark of Genie Industries, Inc in the U.S.A. and many other countries. Genie is a Terex Company. Copyright 2008 Terex Corporation