

Specifications

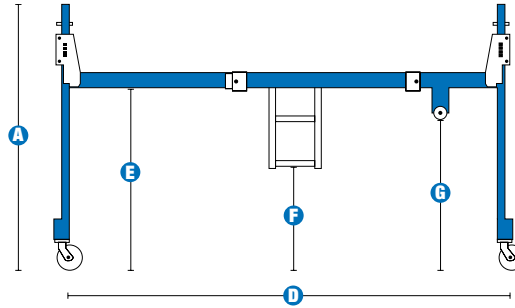
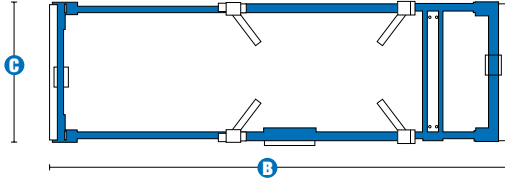

T: 01332 856 359

E: info@workplatformtd.co.uk

www.workplatformtd.co.uk
sales • leasing • hire • training • support

SUPER STRADDLE MODELS		AWP™-20S		AWP™-25S	
MEASUREMENTS	Metric	US	Metric	US	
A Height	1.78 m	5 ft 10 in	1.78 m	5 ft 10 in	
B Length (adjustable)	2.77 – 3.25 m	9 ft 1 in – 10 ft 8 in	2.77 – 3.25 m	9 ft 1 in – 10 ft 8 in	
C Width	.97 m	3 ft 2 in	.97 m	3 ft 2 in	
Width with required outriggers	1.75 m	5 ft 9 in	2.05 m	6 ft 9 in	
D Wheelbase (adjustable)	2.64 - 3.25 m	8 ft 8 in – 10 ft 8 in	2.64 - 3.25 m	8 ft 8 in – 10 ft 8 in	
E Straddle clearance	1.22 m	4 ft	1.22 m	4 ft	
F Height to ladder	.69 m	2 ft 3 in	.69 m	2 ft 3 in	
G Height to fixed wheel	1.02 m	3 ft 4 in	1.02 m	3 ft 4 in	
Storage dimensions (l/w/d)	2.03/0.94/0.61 m	80/37/24 in	2.03/0.94/0.61 m	80/37/24 in	
WEIGHT					
	263 kg	580 lbs	263 kg	580 lbs	

SUPER STRADDLE MODELS		AWP™-30S		AWP™-36S	
MEASUREMENTS	Metric	US	Metric	US	
A Height	1.78 m	5 ft 10 in	1.78 m	5 ft 10 in	
B Length (adjustable)	2.77 – 3.25 m	9 ft 1 in – 10 ft 8 in	2.77 – 3.25 m	9 ft 1 in – 10 ft 8 in	
C Width	.97 m	3 ft 2 in	.97 m	3 ft 2 in	
Width with required outriggers	2.31 m	7 ft 7 in	2.57 m	8 ft 5 in	
D Wheelbase (adjustable)	2.64 - 3.25 m	8 ft 8 in – 10 ft 8 in	2.64 - 3.25 m	8 ft 8 in – 10 ft 8 in	
E Straddle clearance	1.22 m	4 ft	1.22 m	4 ft	
F Height to ladder	.69 m	2 ft 3 in	.69 m	2 ft 3 in	
G Height to fixed wheel	1.02 m	3 ft 4 in	1.02 m	3 ft 4 in	
Storage dimensions (l/w/d)	2.03/0.94/0.61 m	80/37/24 in	2.03/0.94/0.61 m	80/37/24 in	
WEIGHT					
	263 kg	580 lbs	263 kg	580 lbs	

SUPER STRADDLE MODELS		AWP™-40S	
MEASUREMENTS	Metric	US	
A Height	1.78 m	5 ft 10 in	
B Length (adjustable)	2.77 – 3.25 m	9 ft 1 in – 10 ft 8 in	
C Width	.97 m	3 ft 2 in	
Width with required outriggers	2.77 m	9 ft 1 in	
D Wheelbase (adjustable)	2.64 - 3.25 m	8 ft 8 in – 10 ft 8 in	
E Straddle clearance	1.22 m	4 ft	
F Height to ladder	.69 m	2 ft 3 in	
G Height to fixed wheel	1.02 m	3 ft 4 in	
Storage dimensions (l/w/d)	2.03/0.94/0.61 m	80/37/24 in	
WEIGHT			
	263 kg	580 lbs	

Effective date: August, 2008. Product specifications are subject to change without notice or obligation. The photographs and/or drawings in this document are for illustrative purposes only. Refer to the appropriate Operator's Manual for instructions on the proper use of this equipment. Failure to follow the appropriate Operator's Manual when using our equipment or to otherwise act irresponsibly may result in serious injury or death. The only warranty applicable to our equipment is the standard written warranty applicable to the particular product and sale and we make no other warranty, expressed or implied. Products and services listed may be trademarks, service marks or trade-names of Terex Corporation, Genie Industries, Inc. and/or their subsidiaries in the U.S.A. and many other countries and all rights are reserved. Terex is a Registered Trademark of Terex Corporation in the U.S.A. and many other countries. Genie is a Registered Trademark of Genie Industries, Inc in the U.S.A. and many other countries. Genie is a Terex Company. Copyright 2008 Terex Corporation

Features

EASILY CONFIGURED TO MEET YOUR NEEDS

PLATFORM OPTIONS

- Sliding mid-rail standard platform
- Gated standard platform
- Gated ultra narrow platform
- Gated narrow platform
- Standard fibreglass platform
- Narrow fibreglass platform

POWER OPTIONS

- AC power 85 V 50-60 Hz
- AC power 110 V / 50-60 Hz
- AC power 220 V / 50-60 Hz
- DC 12V with 110 V / 230 V/ 50-60 Hz with worldwide automatic “smart” charging system
- Air motor power 1.5 hp (1.1 kW) (AWP™-30 only)

BASE OPTIONS

- Standard base
- Narrow base (AWP™-20, -25, 30 only)
- Rough terrain (RT) base (AWP™-20, -25, 30 only)

OPTIONS & ACCESSORIES

PRODUCTIVITY

- Gated standard platform
- Gated ultra narrow platform
- Gated narrow platform
- Standard fibreglass platform
- Narrow fibreglass platform
- Narrow base conversion kit (AWP™-20, -25, -30 RT only)
- RT conversion kit (AWP™-20, -25, -30 Narrow only)
- Tilt-back frame (option on AWP™-20, -25, -30 only)
- Operational warning light and descent alarm package
- Tool tray
- Fluorescent tube caddy
- Platform locating laser light

POWER

- Air motor power 1.5 hp (1.1 kW) (AWP™-30 only)



Standard Base

STANDARD FEATURES

MEASUREMENTS

AWP™-20S

- 8.12 m (26 ft 1 in) working height
- 6.12 m (20 ft 1 in) platform height
- 74 cm (2 ft 5 in) standard base width
- 56 cm (1 ft 10 in) narrow base width
- 76 cm (2 ft 6 in) RT base width
- Up to 159 kg (350 lb) lift capacity

AWP™-25S

- 9.57 m (30 ft 10 in) working height
- 7.57 m (24 ft 10 in) platform height
- 74 cm (2 ft 5 in) standard base width
- 56 cm (1 ft 10 in) narrow base width
- 76 cm (2 ft 6 in) RT base width
- Up to 159 kg (350 lb) lift capacity

AWP™-30S

- 11 m (35 ft 6 in) working height
- 9 m (29 ft 6 in) platform height
- 74 cm (2 ft 5 in) standard base width
- 56 cm (1 ft 10 in) narrow base width
- 76 cm (2 ft 6 in) RT base width
- Up to 159 kg (350 lb) lift capacity

AWP™-36S

- 13.10 m (42 ft 5 in) working height
- 11.10 m (36 ft 5 in) platform height
- 74 cm (2 ft 5 in) standard base width
- Up to 159 kg (350 lb) lift capacity

AWP™-40S

- 14.29 m (46 ft 4 in) working height
- 12.29 m (40 ft 4 in) platform height
- 74 cm (2 ft 5 in) standard base width
- Up to 136 kg (300 lb) lift capacity

PRODUCTIVITY

- Auxiliary platform lowering
- Most rigid mast in the industry
- Rocker base system for manoeuvrability
- Tilt base frame (standard on AWP™-36, -40)
- Easily rolls through standard doorways
- AC power to platform
- Dual activated up/down switch
- Small outrigger footprints
- Outrigger storage pockets
- Easy loading in pickup trucks
- Tie down attachment points
- Overhead crane attachment points
- Wide forklift pockets
- Rear access forklift pocket
- LED lights confirm proper set-up
- Certified load sensor

POWER

- AC power 85V / 50-60 Hz
- AC power 110V / 50-60 Hz
- AC power 220V / 50-60 Hz
- DC power 110V / 230V/ 50-60 Hz with worldwide automatic “smart” charging system

Specifications

MODELS	AWP™-20S		AWP™-25S		AWP™-30S	
	Metric	US	Metric	US	Metric	US
Working height*	8.12 m	26 ft 1 in	9.57 m	30 ft 10 in	11 m	35 ft 6 in
Platform height	6.12 m	20 ft 1 in	7.57 m	24 ft 10 in	9 m	29 ft 6 in
A Height - stowed (Standard, Narrow)	1.98 m	6 ft 6 in	1.98 m	6 ft 6 in	1.98 m	6 ft 6 in
	2.01 m	6 ft 7 in	2.01 m	6 ft 7 in	2.01 m	6 ft 7 in
B tilted back** (Standard)	1.78 m	5 ft 10 in	1.84 m	6 ft 3 in	1.89 m	6 ft 2.5 in
C Length - stowed (Standard)	1.24 m	4 ft 1 in	1.31 m	4 ft 3.5 in	1.35 m	4 ft 5 in
	1.27 m	4 ft 2 in	1.32 m	4 ft 4 in	1.40 m	4 ft 7 in
	1.60 m	5 ft 3 in	1.60 m	5 ft 3 in	1.60 m	5 ft 3 in
D Length - tilted back**	2.11 m	6 ft 11 in	2.11 m	6 ft 11 in	2.11 m	6 ft 11 in
E Width (Standard)	74 cm	2 ft 5 in	74 cm	2 ft 5 in	74 cm	2 ft 5 in
	56 cm	1 ft 10 in	56 cm	1 ft 10 in	56 cm	1 ft 10 in
	76 cm	2 ft 6 in	76 cm	2 ft 6 in	76 cm	2 ft 6 in

PRODUCTIVITY						
Lift capacity	159 kg	350 lbs	159 kg	350 lbs	159 kg	350 lbs
Indoor:						
F G Outrigger footprint (l/w) (Standard)	1.55 m/1.35 m	5 ft 1 in/4 ft 5 in	1.75 m/1.55 m	5 ft 9 in/5 ft 1 in	1.93 m/1.73 m	6 ft 4 in/5 ft 8 in
	1.63 m/1.27 m	5 ft 4 in/4 ft 2 in	1.63 m/1.27 m	5 ft 4 in/4 ft 2 in	1.83 m/1.52 m	6 ft/5 ft
H Corner access*** (Standard)	38 cm	1 ft 3 in	48 cm	1 ft 7 in	56 cm	1 ft 10 in
	53 cm	1 ft 9 in	51 cm	1 ft 8 in	70 cm	2 ft 3.5 in
I J Wall access front/side (Standard)	15 cm/33 cm	6 in/1 ft 1 in	18 cm/43 cm	7 in/1 ft 5 in	20 cm/53 cm	8 in/1 ft 9 in
	30 cm/43 cm	1 ft/1 ft 5 in	25 cm/43 cm	10 in/1 ft 5 in	23 cm/51 cm	9 in/1 ft 8 in
Outdoor:						
F G Outrigger footprint (l/w) (Standard)	2.46 m/2.26 m	8 ft 1 in/7 ft 5 in	2.97 m/2.79 m	9 ft 9 in/9 ft 2 in	2.97 m/2.79 m	9 ft 9 in/9 ft 2 in
	2.84 m/2.84 m	9 ft 4 in/9 ft 4 in	2.84 m/2.84 m	9 ft 4 in/9 ft 4 in	3.30 m/3.45 m	10 ft 10 in/11 ft 4 in
H Corner access*** (Standard)	48 cm	1 ft 7 in	76 cm	2 ft 6 in	69 cm	2 ft 3 in
	1.37 m	4 ft 6 in	1.32 m	4 ft 4 in	1.55 m	5 ft 1 in
I J Wall access front/side (Standard)	48 cm /81 cm	1 ft 7 in/2 ft 8 in	74 cm/1.07 m	2 ft 5 in/3 ft 6 in	69 cm/1.07 m	2 ft 3 in/3 ft 6 in
	81 cm/1.12 m	2 ft 8 in/3 ft 8 in	74 cm/1.12 m	2 ft 5 in/3 ft 8 in	89 cm/1.40 m	2 ft 11 in/4 ft 7 in
Platform Dimensions: (l/w/h)						
Standard	69 cm/66 cm/1.14 m	27/26/44.75 in	69 cm/66 cm/1.14 m	27/26/44.75 in	69 cm/66 cm/1.14 m	27/26/44.75 in
Gated	69 cm/66 cm/1.14 m	27/26/44.75 in	69 cm/66 cm/1.14 m	27/26/44.75 in	69 cm/66 cm/1.14 m	27/26/44.75 in
Gated ultra narrow	56 cm/46 cm/1.14 m	22/18/44.75 in	56 cm/46 cm/1.14 m	22/18/44.75 in	56 cm/46 cm/1.14 m	22/18/44.75 in
Gated narrow	66 cm/51 cm/1.14 m	26/20/44.75 in	66 cm/51 cm/1.14 m	26/20/44.75 in	66 cm/51 cm/1.14 m	26/20/44.75 in
Standard fibreglass	74 cm/67 cm/1.10 m	29/26.5/43.5 in	74 cm/67 cm/1.10 m	29/26.5/43.5 in	74 cm/67 cm/1.10 m	29/26.5/43.5 in
Narrow fibreglass	66 cm/56 cm/1.10 m	26/22/43.5 in	66 cm/56 cm/1.10 m	26/22/43.5 in	66 cm/56 cm/1.10 m	26/22/43.5 in

POWER		
Power source - AC or DC models	12V DC / 110/50-60 Hz or 220/50-60 Hz AC	12V DC / 110/50-60 Hz or 220/50-60 Hz AC

WEIGHT						
AC models (Standard)	307 kg	677 lbs	330 kg	727 lbs	352 kg	777 lbs
AC models (Narrow/RT)	299 kg	660 lbs	315 kg	694 lbs	331 kg	729 lbs
DC models (Standard)	347 kg	766 lbs	371 kg	817 lbs	393 kg	867 lbs
DC models (Narrow/RT)	340 kg	749 lbs	354 kg	780 lbs	371 kg	818 lbs
Air motor (Standard)	—	—	—	—	352 kg	777 lbs
Air motor (Narrow/RT)	—	—	—	—	331 kg	729 lbs

STANDARDS COMPLIANCE

CE EN280, PB-10-611-03

Specifications

MODELS	AWP™-36S		AWP™-40S	
	Metric	US	Metric	US
MEASUREMENTS				
Working height*	13.10 m	42 ft 5 in	14.29 m	46 ft 4 in
Platform height	11.10 m	36 ft 5 in	12.29 m	40 ft 4 in
A Height - stowed (Standard, Narrow) stowed (RT)	2.78 m	9 ft 1.5 in	2.78 m	9 ft 1.5 in
B tilted back** (Standard)	1.92 m	6 ft 3.5 in	1.98 m	6 ft 6 in
C Length - stowed (Standard) stowed (Narrow) stowed (RT)	1.40 m	4 ft 7 in	1.42 m	4 ft 8 in
D Length - tilted back**	2.97 m	9 ft 9 in	2.97 m	9 ft 9 in
E Width (Standard) Width (Narrow) Width (RT)	74 cm	2 ft 5 in	74 cm	2 ft 5 in
PRODUCTIVITY				
Lift capacity	159 kg	350 lbs	136 kg	300 lbs
Indoor:				
F G Outrigger footprint (l/w) (Standard) Outrigger footprint (l/w) (Narrow/RT)	2.12 m/1.91 m	6 ft 11 in/6 ft 3 in	2.26 m/2.06 m	7 ft 5 in /6 ft 9 in
H Corner access*** (Standard) Corner access*** (Narrow/RT)	74 cm	2 ft 5 in	79 cm	2 ft 7 in
I J Wall access front/side (Standard) Wall access front/side (Narrow/RT)	36 cm/64 cm	1 ft 2 in/2 ft 1 in	38 cm/71 cm	1 ft 3 in/2 ft 4 in
Outdoor:				
F G Outrigger footprint (l/w) (Standard) Outrigger footprint (l/w) (Narrow/RT)	3.53 m/3.33 m	11 ft 7 in/10 ft 11 in	3.89 m /3.68 m	12 ft 9 in/12 ft 1 in
H Corner access*** (Standard) Corner access*** (Narrow/RT)	1.02 m	3 ft 4 in	1.12 m	3 ft 8 in
I J Wall access front/side (Standard) Wall access front/side (Narrow/RT)	1.02 m/1.32 m	3 ft 4 in/4 ft 4 in	1.12 m/1.52 m	3 ft 8 in/5 ft
Platform Dimensions: (l/w/h)				
Standard	69 cm/66 cm/1.14 m	27/26/44.75 in	69 cm/66 cm/1.14 m	27/26/44.75 in
Gated	69 cm/66 cm/1.14 m	27/26/44.75 in	69 cm/66 cm/1.14 m	27/26/44.75 in
Gated ultra narrow	56 cm/46 cm/1.14 m	22/18/44.75 in	56 cm/46 cm/1.14 m	22/18/44.75 in
Gated narrow	66 cm/51 cm/1.14 m	26/20/44.75 in	66 cm/51 cm/1.14 m	26/20/44.75 in
Standard fibreglass	74 cm/67 cm/1.10 m	29/26.5/43.5 in	74 cm/67 cm/1.10 m	29/26.5/43.5 in
Narrow fibreglass	66 cm/56 cm/1.10 m	26/22/43.5 in	66 cm/56 cm/1.10 m	26/22/43.5 in
POWER				
Power source - AC or DC models	12V DC / 110/50-60 Hz or 220/50-60 Hz AC		12V DC / 110/50-60 Hz or 220/50-60 Hz AC	
WEIGHT				
AC models (Standard)	461 kg	1,017 lbs	472 kg	1,040 lbs
AC models (Narrow/RT)	—	—	—	—
DC models (Standard)	502 kg	1,107 lbs	513 kg	1,130 lbs
DC models (Narrow/RT)	—	—	—	—
Air motor (Standard)	—	—	—	—
Air motor (Narrow/RT)	—	—	—	—

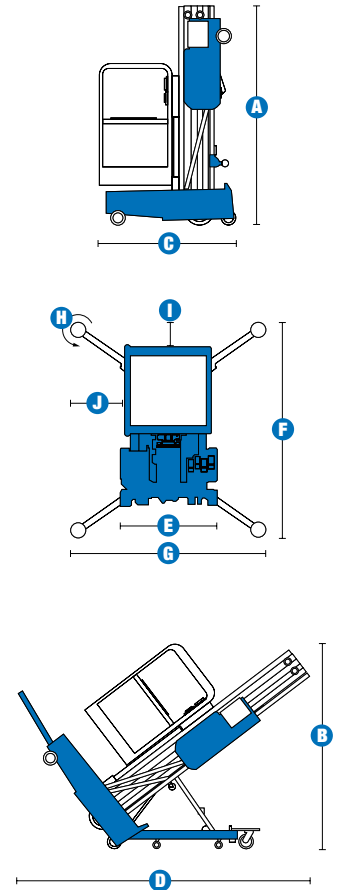

STANDARD COMPLIANCE

CE EN280, PB-10-611-03

* The metric equivalent of working height adds 2 m to platform height. U.S. adds 6 ft to platform height.

** Tilt back height with standard platform. For tilt back height with other platforms, please contact your sales representative.

*** Corner of platform top rail to corner of wall with ability to rotate levelling jack handle.